

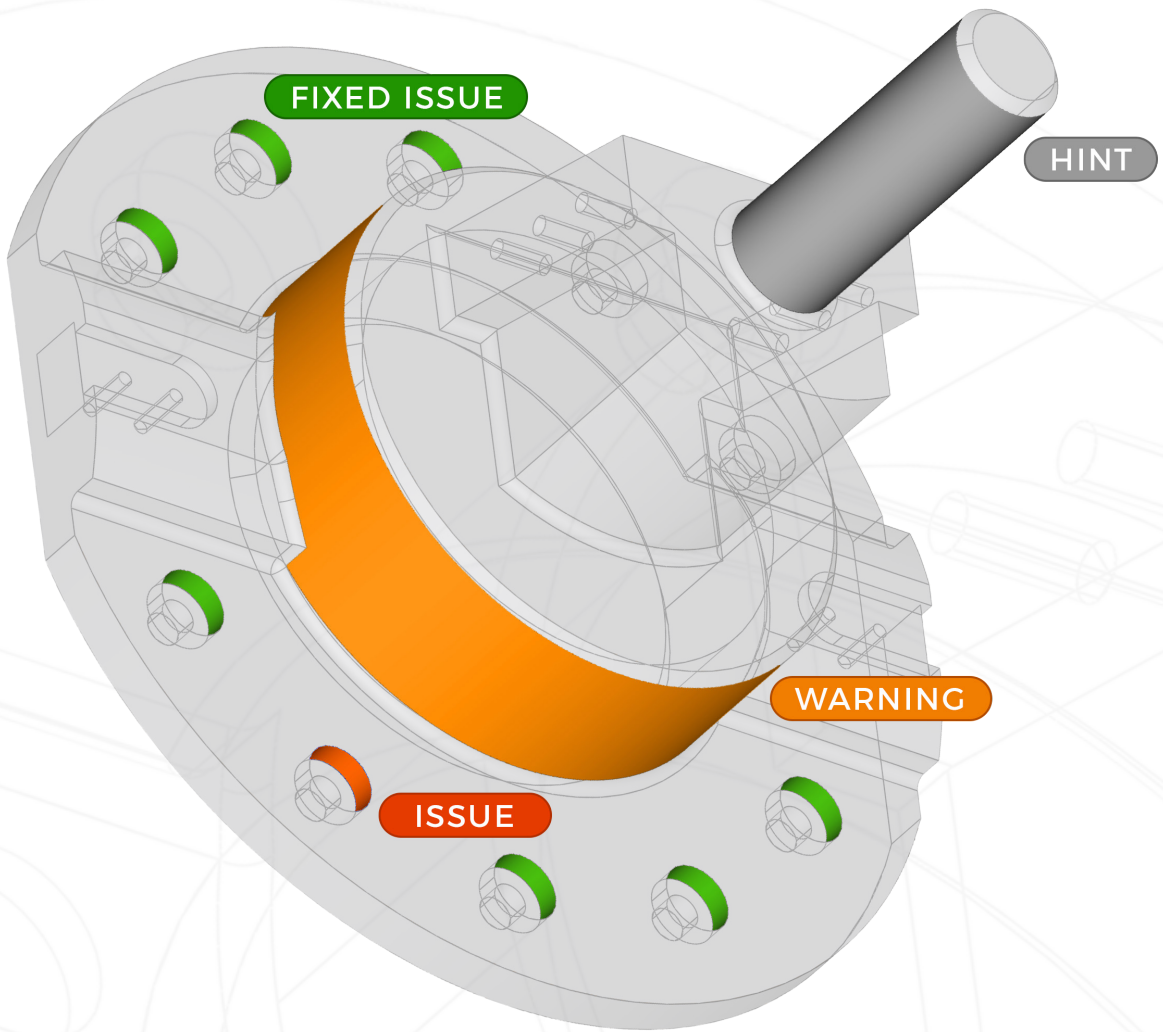

EVOLVE Design



EVOLVE Suite Model-Based Family of Software



EVOLVE Design

Part of the
EVOLVE Software Suite



EVOLVE is a model-based family of software that seamlessly connects Design, Production and Inspection Teams across a manufacturing enterprise. It integrates easily with 3D CAD and CAM, incorporating PMI data automatically.

EVOLVE optimizes the design process and integrates with production, enabling manufacturers to shorten product design/development time, normalize inspection and measurement techniques, improve process control, and manage product tolerances throughout the manufacturing process.

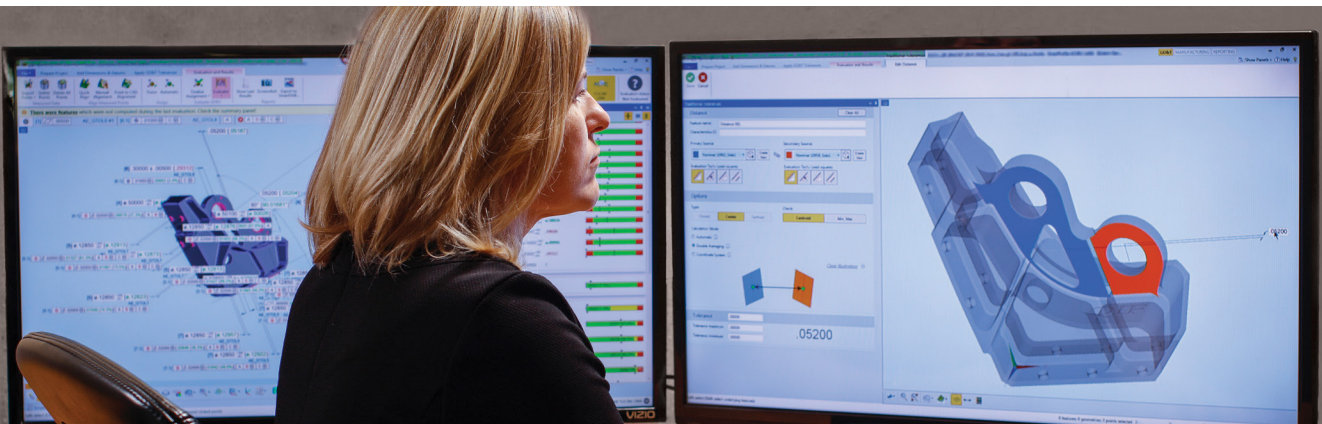

GD&T Proofing in four easy steps

1 Import CAD

Simply import a CAD file into EVOLVE Design where the file can then be proofed for potential tolerancing errors. Users then can save revised files to various formats such as STEP, IGES, QIF, or EVOLVE project files for SmartProfile processing downstream.

2 Import PMI & Define Standards

Using the EVOLVE Design GD&T engine, users can choose from ASME Y14.5M-1994, AMSE Y14.5-2009 or ISO 1101. This helps users specifically apply various GD&T standards to their CAD model, with or without PMI.

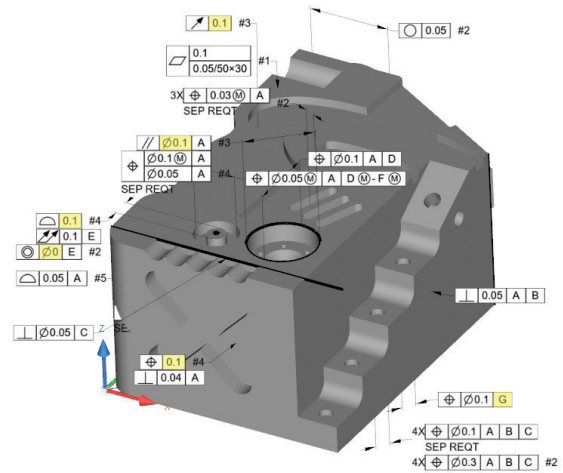

3 Proof GD&T

Powerful GD&T engine processes the CAD file and provides visual notifications of errors and warnings. These errors and warnings are then associated with appropriate details and highlighted on both the textual output and 3D CAD model.

4 Save Results

Once the CAD model proofing has been approved, users can evaluate the new revised model with applied GD&T specifications. The model can then be saved for future reference or a report can be provided for analysis.

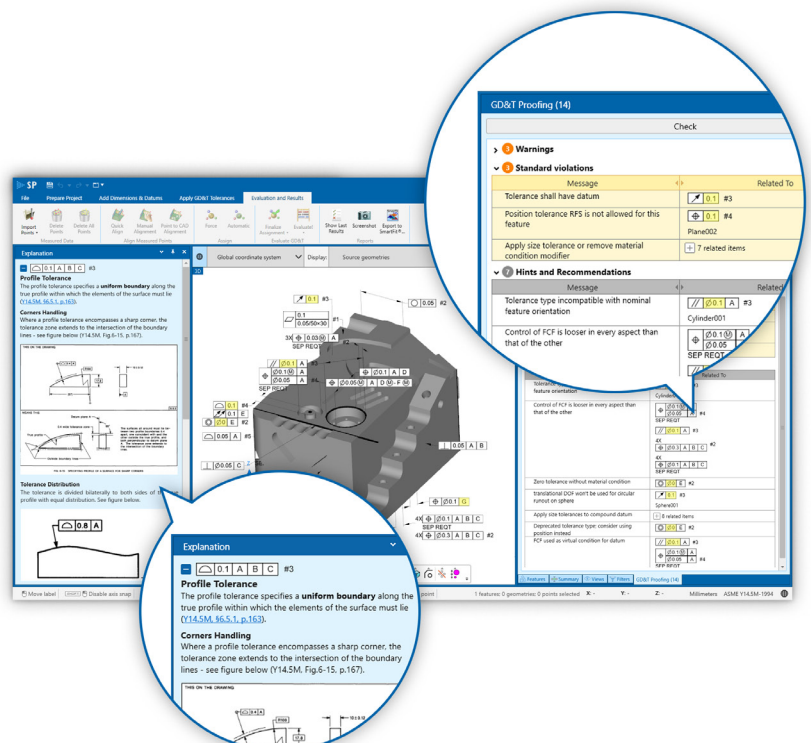



KOTEM

The leader in dimensional analysis software

KOTEM is the worldwide leader in dimensional analysis software. Our family of advanced GD&T and fitting software helps manufacturers integrate quality inspection data with their manufacturing and design work flows. KOTEM is a Quality Vision International company.

QVI® (Quality Vision International) is the world's largest vision metrology company. Founded in 1945, QVI is the world leader in optical, electronic and software technologies for vision and multisensor measuring systems.

To learn more about the EVOLVE family go to www.kotem.com/evolve

EVOLVE is fully compliant with all internationally accepted GD&T Standards:



ISO 1101



ASME Y14.5M-1994



ASME Y14.5-2009